

## Standard Full Nut

**Thread Type:** UNC / BSW - Coarse

**Thread Direction:** Right Hand

**Material:** Solid Brass

**Class Grade:** Low Tensile Grade 2

**Corrosion Protection Level:** Ultimate

**Standard:** HEC Standard

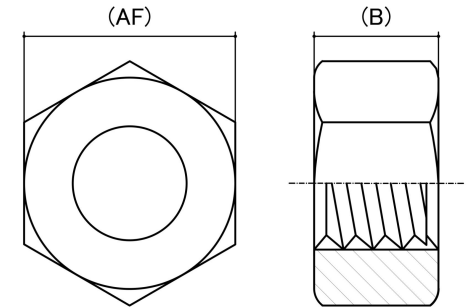

*CAD drawings shown for graphic representation only.\**

Size	Thread Pitch (TPI)	Thread Type	Overall Nut Height (B) (mm)		Across Flats (AF) (mm)		Spanner Size (AF) (inches)	sku (qfind)
			Min	Max	Min	Max		
1/8"	40	Coarse	2.62	3.00	5.49	5.59	15/64	41BW18
5/32"	32	Coarse	3.45	3.70	6.99	7.24	9/32	41BW532
3/16" (#10-24)	24	Coarse	3.94	4.20	8.11	8.23	11/32	41BW316
1/2"	12	Coarse	10.60	10.80	20.62	20.83	7/8	41BW12

**Disclaimer:**

Dimensional data and technical information was obtained from publically available sources and not acquired through standard agencies. It has been completed and compiled for reference purposes only; where discrepancies are found they are subject to change without notice. Bolt & Nut Australia makes no warranties or representations regarding the accuracy and validity of the compiled information and data. Contact the relevant standard authorities for accurate and detailed information.

\* CAD drawings may not reflect diameter, thread length or overall length.

© Bolt & Nut Australia Pty Ltd. All rights reserved.

Version: 18 Mar 2024